

TIPO D

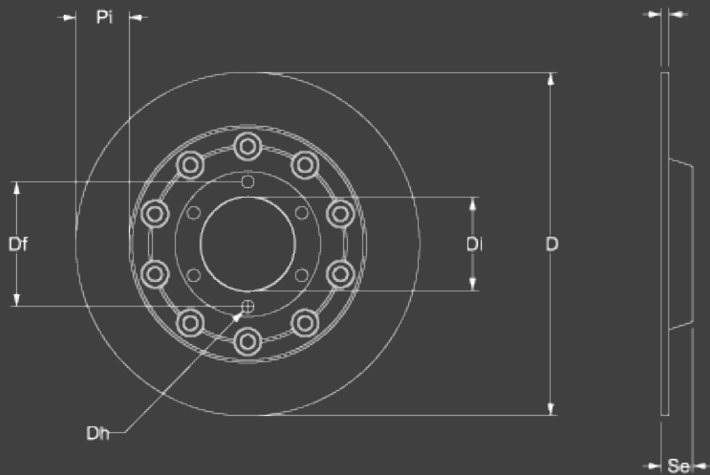

TIPO D										
<i>D</i>	<i>Pi</i>	<i>Di</i>	<i>Df</i>	<i>Dh</i>	<i>N. holes</i>	<i>S</i>	<i>Se</i>	<i>Floating</i>	<i>LIGHTN. ED</i>	<i>MOTORCYCLE</i>
200	34	60	80	8	5	5	20	NO		BULTACO 50 cc
200	34	60	80	8	5	5	20	YES		BULTACO 50 cc
220	34	60	80	8	5	5	20	NO		MBA, MOTOBECANE 125cc
220	34	60	80	8	5	5	20	YES		MINARELLI 125 cc
229	48	64	80	8	6	7	11	YES		YAMAHA 250/3250cc
230	37	60	80	8	6	6	20,25	NO		BIMOTA 250/350cc
230	37	60	80	8	6	6	20,25	YES		BIMOTA 250/350cc
230	42	67	86	10	4	6,5	23,8	NO		DUCATI 750 SS
260	37	60	80	8	6	6	20,25	YES		BIMOTA, MBA 250cc
260	37	60	80	8	6	6	20,25	YES	YES	BIMOTA, MBA 250cc
260	42	80	101,5	8	6	6,5	27,3	YES		BIMOTA
280	37	60	80	8	6	6	20,25	YES	YES	MBA 250cc
280	42	80	101,5	8	6	6,5	27,3	YES		BIMOTA
285	42	60	78	8	6	6,5	26	YES	YES	SUZUKI 500cc
297	48	64	80	8	6	7	22,5	YES	YES	YAMAHA 250/350/500cc
300	42	80	101,5	8	6	6,5	27,3	YES	YES	MORBIDELLI 500cc
300	42	80	78	8	6	6,5	26	YES	YES	SUZUKI 500cc